

## 16 Inch White Pedestal Fan



**DFI655**

Batch code:

**Please read these instructions carefully before use and retain for future reference**

**Before switching on your appliance,  
always check for any damage which may have been caused in transit**

## **CONTENTS**

Important Safety Instructions.....	3-4
Specification .....	5
Appliance Overview .....	6
Assembly Instructions.....	6-7
Operating Instructions.....	8
Cleaning and Maintenance .....	9
Fuse Replacement.....	9
Trouble Shooting Guide.....	10
Disposal Information.....	10
Igenix Warranty Terms and Conditions.....	14-15

## IMPORTANT SAFETY INSTRUCTIONS

Read and follow all of the instructions even if you feel you are familiar with the product, and find a place to keep this manual handy for future reference.

**Important:** This appliance is intended for use in a domestic environment only. Any other use is not recommended by the manufacturer and may cause fire, electrical shocks or other injury to user or property. When using electrical appliances, basic safety precautions should always be followed:

- Before plugging in the appliance, check that the voltage indicated on the rating label corresponds with the main voltage in your home.
- Do not operate the unit with a damaged cord or plug, after it malfunctions or has been dropped or damaged in any way. Return to an authorised service facility for examination and repair.
- Ensure that the air inlets and outlets are not blocked or covered.
- Do not place the unit too close to curtains or other objects - min 30cm.
- Make sure there are no objects near the unit which can prevent it from oscillating.
- Never insert fingers pencils or other objects into the unit if the power cord is plugged in, and especially not during the operation. Warn your children against these dangers.
- This appliance can be used by children aged from 8 years and above if they have been given supervision or instruction concerning the use of the appliance in a safe way and understand the hazards involved.
- Cleaning and user maintenance shall not be made by children unless they are older than 8 years and supervised.
- Keep the appliance and its cord out of reach of children.
- Children shall not play with the appliance.
- Appliances can be used by persons with reduced physical,

sensory or mental capabilities or lack of experience and knowledge if they have been given supervision or instruction concerning use of the appliance in a safe way and understand the hazards involved.

- Unplug the unit from the socket when not in use. Do not pull on the cord.
- Do not use the unit near bath, shower, swimming pool or anywhere it could be splashed with water.
- Do not expose the unit to direct sunlight.
- Do not immerse the appliance or the electrical cord or plug in any type of liquid.
- Do not use the appliance near a source of heat.
- Do not use the unit near flammable or explosive gases.
- Before cleaning the unit, switch it off and unplug the power cord.
- Do not leave the unit unattended during operation. Always unplug the power cord when not in use.
- To repair the unit, take it to a qualified service engineer. Repairs carried out by unqualified people may cause damage to the unit or injury to persons or property and void the warranty.

## SPECIFICATION

Model No:	DFI 655
Brand	Igenix
Colour	White
Wattage (W)	50 W
Frequency (Hz)	50 Hz
Voltage (V)	220-240 V
Product Dimensions (mm)	H 1240 x W 620 x D 620 mm
Net Weight (kg)	2.5 kg
Oscillation Function	Yes
Class	II 
Speeds	Low, Medium, High

## APPLIANCE OVERVIEW

Fig 1:

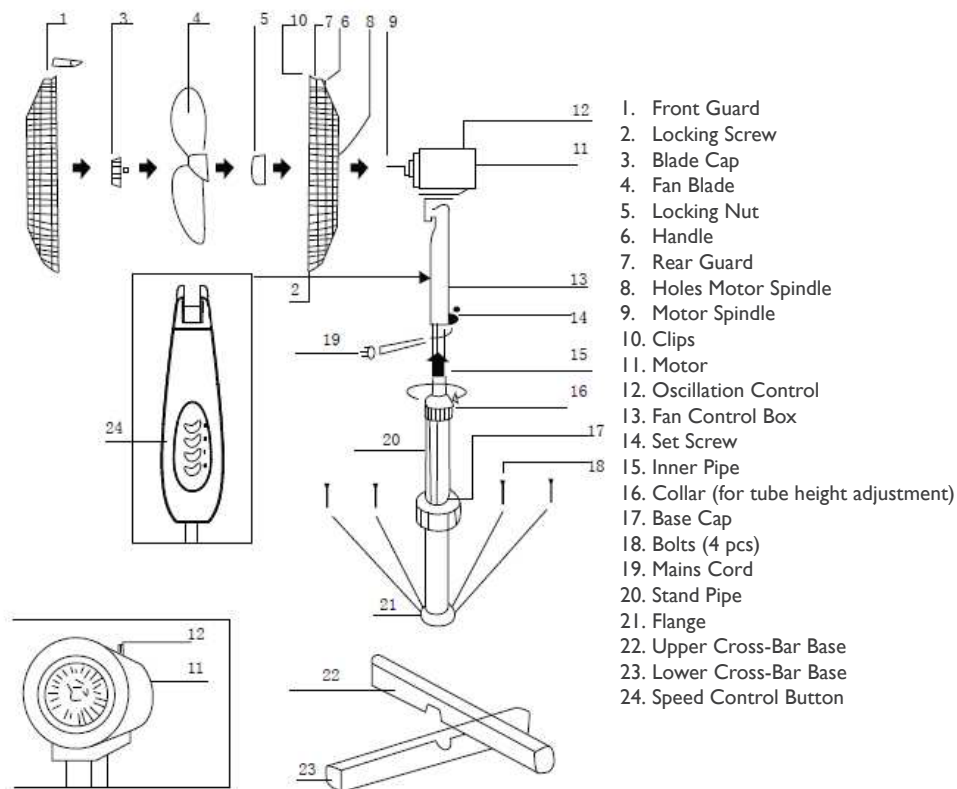

## ASSEMBLY INSTRUCTIONS

### Before Assembling

- Check that you have all of the component parts following the content list (fig 1) and familiarise yourself with each part before proceeding.
- Ensure you have enough space to lay out all the parts before assembly.
- Take all the parts out of the plastic bag and separate them into their groups.
- To avoid scratching, it is recommended that you assemble the appliance on a soft level surface

## Assembly

- Loosen and remove the four bolts (18) from the two bars of the base (22 & 23). Cross the two bars as shown in fig 1.
- Position the flange (21) on the base and align the holes.
- Secure the flange to the base with the four bolts.
- Remove the collar (16) from the stand pipe (20).
- Slide the base cap (17) down over the assembly and replace the collar (16).
- Loosen the set screw (14).
- Slide the fan control box (13) down over the inner piper (15) until it contacts the inner stopper, aligning the groove in the upper end of the inner pipe with the set screw.
- Tighten the screw (14) by turning clockwise with a screw driver.
- Unscrew the blade cap (3) from the motor spindle (9) by turning clockwise.
- Remove the transparent plastic tube from the motor spindle (9), if applicable.
- Unscrew the locking nut (5) from the spindle end of the motor by turning the locking nut anti-clockwise.
- Mount the rear guard (7) onto the motor by matching the holes on the rear guard to the pins in the front of the motor. Push it firmly until the pins protrude through the holes.
- Secure the rear guard (7) to the motor unit with the locking nut (5).
- Insert the fan blade (4) onto the motor spindle so that the flattened side of the central hold corresponds with the flattened side of the spindle. Press firmly until the fan blade stops.
- Secure the fan blade with the blade cap (3), turning anti-clockwise to tighten. Hold the fan blade whilst doing so.
- Test fan blade operation by rotating it with your hand. There should be no friction with the locking nut (5). If the blade does not rotate freely, disassemble and repeat the procedure.
- Remove the packing from the front guard (1).
- Open the four clips (10) by moving the lip of the clip outwards.
- Unscrew the locking screw (2) mounted on the rear guard (7). Mount front guard (1) onto rear guard (7) with the small round holes on the bottom matched for the passage of locking screw. Fix both guards with clips and then use screwdriver to tighten the locking screw (2).
- Secure the two guards by moving the lip inwards.

# OPERATING INSTRUCTIONS

## On/Off and Speed Control

The on/off and speed is controlled by the button switch.

- 0 = Off
- 1 = Low
- 2 = Medium
- 3 = High

## Height Setting

- Loosen the height adjustment collar (16) by turning it anti-clockwise (fig 2).
- Pull the inner pipe (15) upwards to the desired height (fig 3).
- Re-tighten the collar by turning firmly clockwise (fig 4).

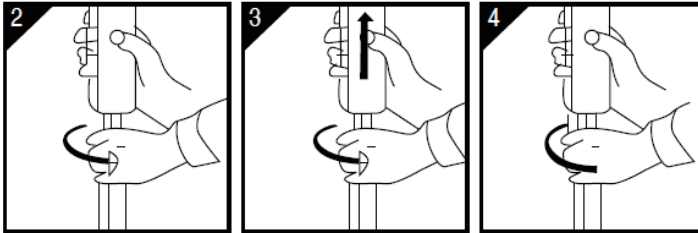

## Angle Adjustment

Switch off the fan. Slightly loosen the adjusting screw by turning it anti-clockwise. Adjust the fan to the desired angle and then tighten the adjusting screw by turning it clockwise.

## Oscillation Adjustment

Push the oscillation control to turn on the oscillation function. Pull the oscillation control to turn it off.



## CLEANING AND MAINTENANCE

- Turn off the fan and remove the plug from the power supply before cleaning.
- Use a dry, soft cloth to remove any dust from the fan.
- If the fan is particularly dirty, use a soft damp cloth and wipe dry.
- Do not use any chemicals or detergents as they will damage the fan.
- It is recommended to cover the fan with a plastic bag before storage to prevent dust collecting on fan blades.
- Store the fan in a ventilated and dry area.
- Do not allow water to get inside the body of the fan.

## MAINS PLUG FUSE REPLACEMENT

### Fuse Replacement (Class II)

Remove the fuse cover with a small flat head screw driver. Take out the fuse and replace with a new fuse of the same Amp. Replace the fuse cover and push back into place.



## TROUBLE SHOOTING GUIDE

If you experience difficulties with the appliance, please check the suggestions below before contacting customer services on 01473 271272:

Problem	Possible Cause	Possible Solution
The appliance does not work.	The appliance is not properly plugged into the wall socket.	Plug the appliance in firmly.
	The appliance is not switched on.	Make sure the appliance is switched on.
	There is no electricity running through the mains wall socket.	Check the fuse or breaker.

## DISPOSAL INFORMATION

The European Directive 2012/19/EU on Waste Electrical and Electronic Equipment (WEEE), requires that old household electrical appliances must not be disposed of in normal unsorted municipal waste.

Old appliances must be collected separately in order to optimise the recovery and recycling of the materials they contain and reduce the impact on human health and the environment.

The crossed out “wheeled bin” symbol on the product reminds you of your obligation, that when you dispose of the appliance it must be separately collected. Consumers should contact their local authority or retailer for information concerning the correct disposal of their old appliance.











## Igenix Warranty Terms & Conditions

This product is guaranteed for a period of 12 months as standard from the date of purchase against mechanical and electrical defects. You can extend your warranty for a further 12 months by registering your product.

Upon registration we will cover your product for a period of 24 months from the original purchase date against any mechanical or electrical defects.

To qualify for the guarantee, the product must be used for domestic household use only and in accordance with the instructions in the user manual. Any misuse of the product will result in the warranty being void.

The guarantee does not cover accidental damage, misuse, neglect, tampering or incorrect adjustment or installation.

The guarantee will be rendered invalid if the product is resold, has had its serial number removed (or has an invalid serial number), or if an unauthorised person has carried out any repairs or alterations.

The warranty does not cover accessories or consumable parts that require replacement under normal use. This includes shelving, dials, filters, belts and trays etc.

In the unlikely event of a breakdown please refer to the Troubleshooting guide in your user manual and check all plugs, fuses and the electricity supply.

If you still require assistance please contact our Customer Service department on **01473 271 272** or write to us at the following address:

**Customer Service Department  
38 Bluestem Road, Ransomes Europark  
Ipswich, IP3 9RR**

Please quote the Product Code which begins 'IG' or 'DF' and the Batch Code beginning '5' and give details of the exact fault. We will then decide whether to repair or replace the item.

Before we arrange the repair or replacement you will be required to return a copy of your proof of purchase. Please retain your original.

If an item is replaced within the agreed guarantee period, the guarantee for the replacement item will be calculated from the purchase date of the original.

In the event that the product is inspected and no fault is found or the product is not within the guarantee period you will be charged for the repair and any carriage costs.

# igenix

## Thank you for choosing Igenix

As a valued customer we would like to offer you a FREE 2 year warranty to cover your product against any electrical or mechanical defects.

This means that in the unlikely event you develop a fault or problem with your product we will happily repair or replace the item free of charge.

To qualify for the 2 year warranty you must register your product within 30 days of purchase. The full Terms & Conditions of our warranty policy are shown on the opposite page. They are also available on our website. **www.igenix.co.uk**

To register your product, please complete all sections of the form below and return to us at the following address: Igenix, 38 Bluestem Road, Ransomes Europark, Ipswich, IP3 9RR.

Alternatively you can visit the Igenix website and complete the form online.

### Customer Details:

Title: \_\_\_\_\_ First Name \_\_\_\_\_ Surname: \_\_\_\_\_

Address: \_\_\_\_\_

Post Code: \_\_\_\_\_

Email: \_\_\_\_\_

Telephone: \_\_\_\_\_

### Product Information:

Product Code (Beginning IG or DF): \_\_\_\_\_ Product Description: \_\_\_\_\_

Batch Number (Beginning 5): \_\_\_\_\_ Serial Number (If applicable): \_\_\_\_\_

Date of Purchase: \_\_\_\_\_

Retailer Name: \_\_\_\_\_

Retailer Location: \_\_\_\_\_

Please tick here to confirm you have read and accept our Terms & Conditions

Please tick here if you DO NOT wish to receive marketing information from us

Customer Signature: \_\_\_\_\_ Date: \_\_\_\_\_

# **igenix**

**38 Bluestem Road, Ransomes Europark, Ipswich, IP3 9RR**

**Tel. 01473 271 272**

Disclaimer: Igenix operate a policy of continual improvement and development.  
We therefore reserve the right to change/alter the specification and appearance of our appliances without prior notice.  
All diagrams and images shown in this manual are for illustration purposes only.